

FilterBox Hygiene 12A

50 Hz

Automatically cleaned for heavier hygienic applications.

The FilterBox Hygiene 12A is equipped with a powerful fan for a maximum air flow capacity of 1 200 m³/h (700 CFM). An integrated silencer reduces noise from the fan and outlet air.

The model has automatic cleaning with an advanced filter control system that starts the cleaning process automatically when the air flow is too low.

The unit is available either as a mobile unit on wheels or attached to a floor stand. Additional protection from harmful particles is provided if a HEPA H13 filter is installed.

Standard features

- 3 m (10 ft.) Nederman Original CR extraction arm
- Dust free emptying of dust bin
- Ergonomic change of filter cartridge
- Polyester filter cartridges or antistatic version, with 99 % separation efficiency
- Silencer
- Integrated LCD display
- Automatic damper minimizing dust leakage during pneumatic cleaning
- Easily maneuverable extractor arm
- 9.5 m (31 ft.) power cable

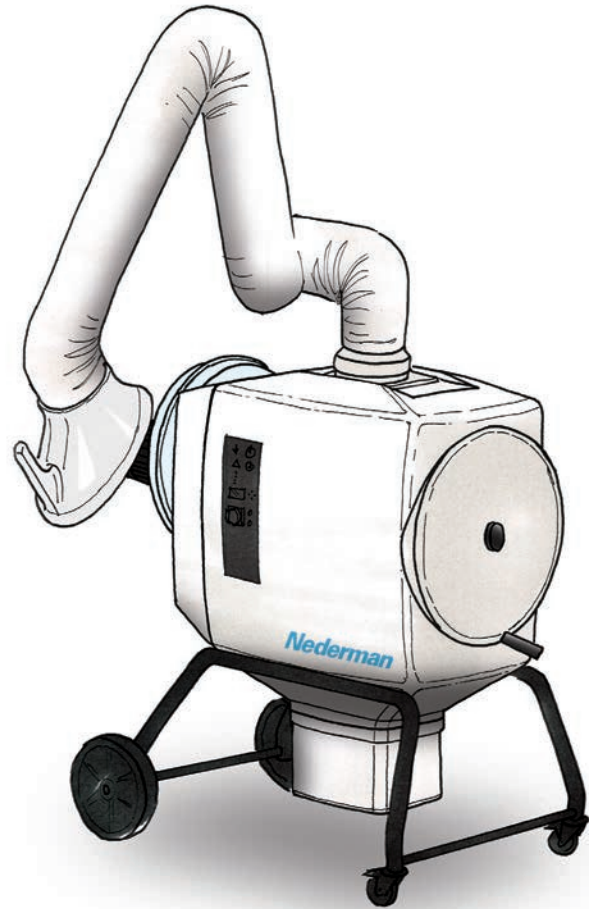

Dimensions

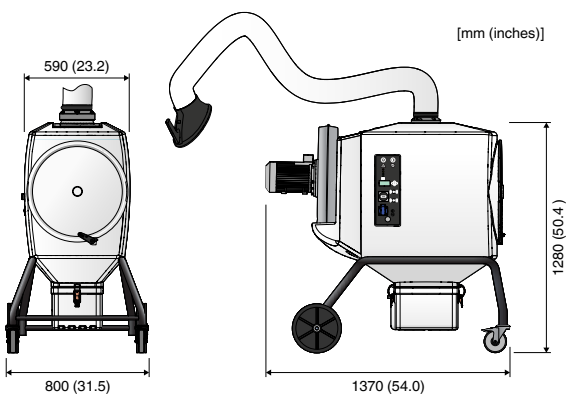

Technical Data

Air flow	Up to 1 200 m ³ /h (700 CFM)
Fan	N29 2.2 kW/3.0 hp
Filter cartridge	<ul style="list-style-type: none"> • 13 m² PW13, polyester • 15 m² PWA HE15 Antistatic
Filtration efficiency	99 %*
Weight	115 kg (254 lbs)
Noise level	74 dB(A)
Extraction hose diam.	160 mm (6 ¼ in)

* average weight filtration efficiency

Models

Filter cleaning method	Filter cleaning system	Filter type	Fan motor power	Voltage (V)	Frequency (Hz)	Phases	Assembly	
							Mobile	Floor
Mechanical	Automatic	PW13	2.2 kW (3.0 hp)	230	50	3	12674963	12675063
Mechanical	Automatic	PW13	2.2 kW (3.0 hp)	400	50	3	12675163	12675263
Mechanical	Automatic	PWA HE15	2.2 kW (3.0 hp)	230	50	3	12680163	12680263
Mechanical	Automatic	PWA HE15	2.2 kW (3.0 hp)	400	50	3	12680363	12680463

Accessories

Accessory	Description	Article number
HEPA filter	Filtration efficiency 99.95 % (H13)	12376615
Spotlight/Fan switch on hood (Original)	Placed on hood	10551235
Fan switch on hood (Original)	Placed on hood	10371080
Spotlight on hood (Original)	Placed on hood	12376616
Ergonomic handle	For improved mobility	12376617
Plastic bag	Bags for dust bin	12376618

Replacement filters

Replacement filters	Used for	Filtration efficiency (%)	Filter surface, m ² (ft ²)	Article number
HEPA filter	Higher filtration efficiency	99.95 % (H13)	10 (108)	12376615
Standard filter cartridge PW13	Welding, dust	99	13 (140)	12332672
High efficiency filter cartridge PWHE15	Dust, stainless steel welding	99.9	15 (162)	12371106
Antistatic high efficiency filter cartridge PWAHE15	Dust	99.9	15 (162)	12371412