

# FilterBox Hygiene 10M

50 Hz

**A cost efficient manually cleaned unit for light to medium hygienic applications.**

FilterBox Hygiene 10M is a mobile unit equipped with a N24 fan for a maximum air flow capacity of 1 000 m<sup>3</sup>/h (600 CFM). An integrated silencer reduces noise from the fan and outlet air.

The filter cartridge has manual mechanical cleaning. There is an alarm indicating too low air flow, and there is also an hour counter feature included.

Additional protection from harmful particles is provided if a HEPA H13 filter is installed.

### Standard features

- 3 m (10 ft.) Nederman Original CR extraction arm
- Dust free emptying of dust bin
- Ergonomic change of filter cartridge
- Polyester filter cartridges with 99% separation efficiency
- Silencer
- Filter indicator with alarm
- Operating hours meter
- Automatic damper minimizing dust leakage during pneumatic cleaning
- Easily maneuverable extractor arm
- 9.5 m (31 ft.) power cable

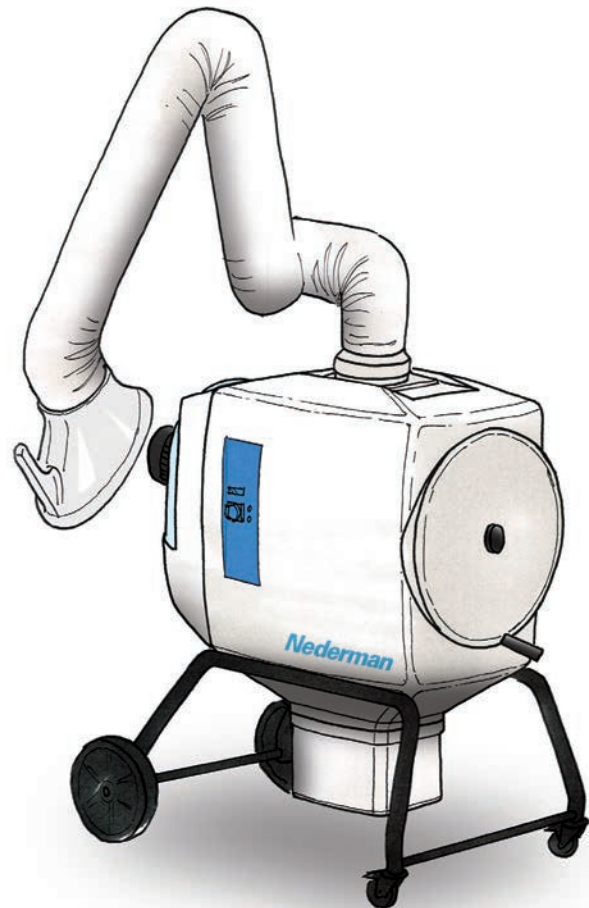

### Dimensions

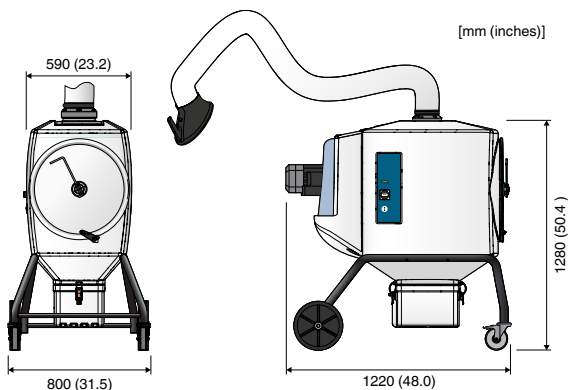

### Technical Data

Air flow	Up to 1000 m <sup>3</sup> /h (600 CFM)
Fan	N24, 0.9 kW/1.2 hp (0.75 kW/1 hp single phase)
Filter cartridge	13 m <sup>2</sup> PW13, polyester
Filtration efficiency	99 %*
Weight	102 kg (225 lbs)
Noise level	66 dB(A)
Extraction hose diam.	160 mm (6 ¼ in)

\* average weight filtration efficiency

## Models

Assembly	Filter cleaning system	Filter type	Fan motor power	Voltage (V)	Frequency (Hz)	Phases	Filter cleaning method	Article number
Mobile	Manual	PW13	0.9 kW (1.2 hp)	230	50	3	Mechanical	12669163
Mobile	Manual	PW13	0.9 kW (1.2 hp)	400	50	3	Mechanical	12669263
Mobile	Manual	PW13	0.75 kW (1.0 hp)	230	50	1	Mechanical	12669363
Mobile	Manual	PW13	0.75 kW (1.0 hp)	110	50	1	Mechanical	12669463

## Accessories

Accessory	Description	Article number
HEPA filter	Filtration efficiency 95.95 % (H13)	12376615
Spotlight on hood (Original)	Mounted on hood	12376616
Ergonomic handle	For improved mobility	12376617
Plastic bag	Bags for dust bin	12376618

## Replacement filters

Replacement filters	Used for	Filtration efficiency (%)	Filter surface, m <sup>2</sup> (ft <sup>2</sup> )	Article number
HEPA filter	Higher filtration efficiency	99.95 % (H13)	10 (108)	12376615
Standard filter cartridge PW13	Welding, dust	99	13 (140)	12332672
High efficiency filter cartridge PWHE15	Dust, stainless steel welding	99.9	15 (162)	12371106
Antistatic high efficiency filter cartridge PWAHE15	Dust	99.9	15 (162)	12371412